

MAJOR SERIES FILTER PRESS 630 mm PLATE

MODEL	CAPACITY Ft ³	NO. of PLATES	FT ³ / CHAMBER	L In.	H In.	C In.	W In.	DRY WEIGHT lbs.
M630-2.0	2.0	8	0.3	73	51	24	42	1376
M630-3.0	3.0	11	0.3	80	51	24	42	1454
M630-4.0	4.0	14	0.3	87	51	24	42	1558
M630-5.0	5.0	18	0.3	96	51	24	42	1662
M630-6.0	6.0	21	0.3	103	51	24	42	1765
M630-7.0	7.0	24	0.3	109	51	24	42	1868
M630-8.0	8.0	27	0.3	116	51	24	42	1971
M630-10.0	10.0	33	0.3	132	51	24	42	1971
M630-12.0	12.0	39	0.3	148	51	24	42	1971
M630-14.0	14.0	45	0.3	x	51	24	42	1971
M630-15.0	15.0	48	0.3	x	51	24	42	1971

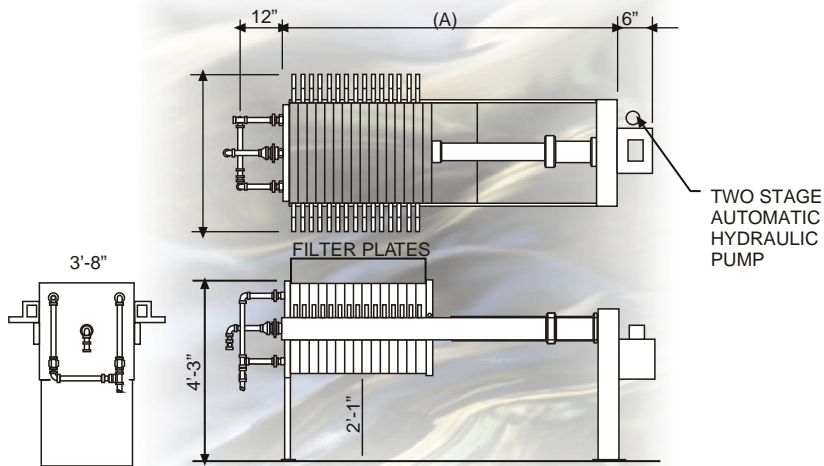

JUNIOR SERIES FILTER PRESS 630 mm PLATE

MODEL	CAPACITY Ft ³	NO. of PLATES	FT ³ / CHAMBER	L In.	H In.	C In.	W In.	DRY WEIGHT lbs.
J630-0.6A	0.6	3	0.3	48	51	24	42	1376
J630-1.0A	1.0	5	0.3	54	51	24	42	1454
J630-2.0A	2.0	8	0.3	59	51	24	42	1558
J630-3.0A	3.0	11	0.3	66	51	24	42	1662
J630-4.0A	4.0	14	0.3	73	51	24	42	1765
J630-5.0A	5.0	17	0.3	80	51	24	42	1868
J630-6.0A	3.0	21	0.3	87	51	24	42	1971

Note: All dimensions are approximate & are subject to change without notice. Please contact factory for drawings and specifications.

All presses are supplied complete with Filter Plates:

- CRN Gasketed Filter Plates: 630mm x 630mm HD Polypropylene
- Recessed Chamber: Center feed, Four corner discharge
- Cake Thickness: 1-1/4"
- Non-Gasketed plates are available
- Consult factory for optional plate materials

OPTIONAL Equipment

Pneumatic plate shifters

Semi-automatic or fully-automatic plate shifting systems are available on all Kontek filter presses



Manifold Systems

Manifold systems are available in the following materials:



PVC • CPVC • Polypropylene
Kynar (PVDV) • Stainless Steel

Manifold systems are available with manual or automatic valving for:

- Clean In Place cloth cleaning systems
- Filter cake washing systems
- Automatic air blow-down systems
- Filter cloth precoating.

Automatic Pump Pressure Control Systems

Kontek PPCS Automatic Pump Pressure Control System automatically increases the feed pump pressure in three stages throughout the filter press cycle.



The PPCS monitors the hydraulic cylinder pressure and automatically stops the feed pump should a drop in hydraulic pressure occur.

The PPCS system automatically stops the feed pump at the end of the filter cycle and alerts the operator to the "Press Cycle Complete" (Optional models can start and stop a timed air blow down cycle)

Hoppers and Drip Trays

Self dumping hoppers with safety chain and heavy duty corrosion resistant swivel casters.



Steel or Polypropylene slide out drip trays prevent any seepage from contaminating shop floor or dumpsters.

Bomb bay style drip trays, custom mezzanines and discharge chutes are also available.

Membrane Plate Filter Presses

Membrane Plate filter presses are available in Major Press styles only. Membrane System benefits are shorter filter press cycles, higher efficiency cake washing, and dryer filter cake. Filter cake is squeezed up to 225 PSI (15 Bar) to remove moisture from the filter cake.

